

Industrial SD Card

ISDD33K



The ADATA ISDD33K industrial-grade SD card implements 3D TLC Flash and sports a 3K P/E cycle rating for great durability and high capacity. In addition, it also meets the V10 (Video Speed Class) standard for high-quality recording. For excellent data integrity, the ISDD33K supports LDPC ECC (Error Correcting Code) and Wear Leveling technologies. The ISDD33K is highly reliable and compatible as well as power efficient, and is ideally suited for applications such as industrial automation, surveillance, POS, healthcare and more.

Features

- Compliant with SD 5.1 specifications
- 3K P/E Cycles – improved endurance and reliability
- Meets V10 (Video Speed Class) standard
- Wide temperature support: -40°C to 85°C
- LDPC ECC (error correction) Technology
- Supports Wear Leveling, Garbage Collection and Bad Block Management
- Suitable for automation, surveillance, healthcare, POS, in-vehicle, and handheld devices

Ordering Information

Operating Temp.	16GB	32GB	64GB	128GB
-25°C to 85°C	ISDD33K-016GR	ISDD33K-032GR	ISDD33K-064GR	ISDD33K-128GR
-40°C to 85°C	ISDD33K-016GP	ISDD33K-032GP	ISDD33K-064GP	ISDD33K-128GP

Specifications

Model	ISDD33K
Form Factor	SD
Capacity	16GB – 128GB
Interface	SD 5.1
Flash Type	64L 3D TLC
Dimensions (L x W x H)	32 x 24 x 2.1mm
Sequential Read (Max.)	97MB/s
Sequential Write (Max.)	84MB/s
Speed Class	UHS Speed : Class 1/ Speed Class : Class 10/ Video Speed Class : V10
Operating Temperature (Standard)	-25°C to 85°C
Operating Temperature (Industrial)	-40°C to 85°C
Operating Voltage	DC 2.7V – 3.6V
Power Consumption (Max)	0.45W
Shock Resistance	1500G/0.5ms, Half Sine Wave
Operating Humidity	5%-95% RH, non-condensing
Vibration Resistance	20G (20-2000Hz)
Technologies	LDPC ECC, Wear Leveling, Garbage Collection, Bad Block Management

Diagram

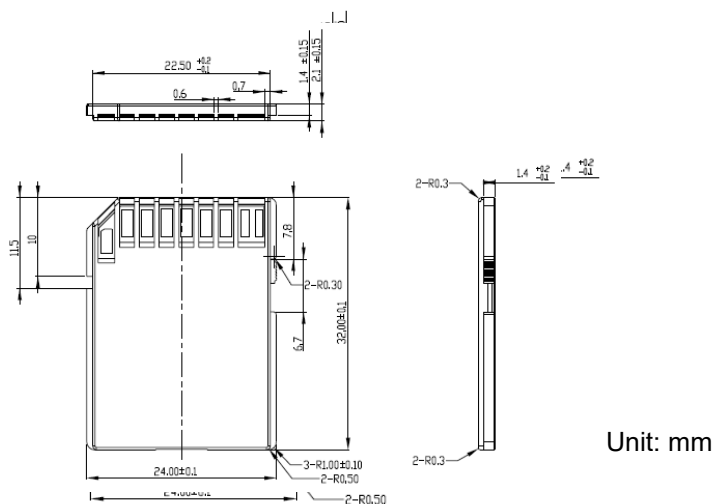

Contact Us

HQ (Taiwan):

T: +886-8228-0886

E: adata@adata.com

US:

T: +1-714-332-8708

E: IASales_us@adata.com

EU:

T: +49-899-0405-296

E: IASales_eu@adata.com

China

T: +86-21-6233-1010

E: IASales_cn@adata.com

JP:

T: +81-3-5807-0011

E: IASales_jp@adata.com

APAC/MEA:

E: IASales_apacmea@adata.com